**TAB  
7559**

TAB 4.3 Due Fili Plus hands-free video entryphone

The instructions manual can be downloaded from the website [www.vimar.com](http://www.vimar.com)

## Installation rules

Installation must be carried out by qualified persons in compliance with the current regulations regarding the installation of electrical equipment in the country where the products are installed.

## Regulatory compliance

EMC directive

Standards EN 60065, EN 61000-6-1, EN 61000-6-3 and EN 60118-4..



### WEEE - User information

The crossed bin symbol on the appliance or on its packaging indicates that the product at the end of its life must be collected separately from other waste. The user must therefore hand the equipment at the end of its life cycle over to the appropriate municipal centres for the differentiated collection of electrical and electronic waste. As an alternative to independent management, you can deliver the equipment you want to dispose of free of charge to the distributor when purchasing a new appliance of an equivalent type. You can also deliver electronic products to be disposed of that are smaller than 25 cm for free, with no obligation to purchase, to electronics distributors with a sales area of at least 400 m<sup>2</sup>. Proper sorted waste collection for subsequent recycling, processing and environmentally conscious disposal of the old equipment helps to prevent any possible negative impact on the environment and human health while promoting the practice of reusing and/or recycling materials used in manufacture.

This product was developed using FreeRTOS™ software - <http://www.freertos.org/>

## Description

Wall-mount Tab series hands-free video entryphone for Due Fili Plus system with 4.3" LCD colour display, loudspeaker for calls, capacitive keypad for entryphone functions (unlocking, self-starting, auxiliary services, volume, brightness and contrast controls) and intercom calls.

Desktop installation is possible with the desktop base accessory 753A (sold separately).

Can be used by hearing aid wearers.

## Technical characteristics

- Wall-mounted, with metal bracket, in box: circular 2M (Vimar V71701), 3M (Vimar V71303, V71703) horizontal/vertical and square British standard.
- LCD 4.3" 16:9 display, resolution 480x272 pixels
- Minimum video signal level on the bus for reception: -20 dBm
- Capacitive touch keypad with backlit symbols.
- Powered from BUS terminals 1, 2 - nominal voltage 28Vdc
- Power consumption:
  - in standby: 17 mA
  - maximum current: 280 mA
- Ambient class: Class A1 (indoor use)
- IP30 protection rating
- Operating temperature: -5°C to +40°C (indoor use)
- Electronic ringtone with 10 different melodies.
- Input for landing call.
- Dimensions: 155 x 145 x 23.5 mm
- DIP switch for line termination impedance.

## Audio frequency function for hearing aids (Teleloop)

The video entryphone can be used by people wearing hearing aids.

For correct functioning of the hearing aid, please refer to its instruction manual. Any metal objects or electronic equipment in the vicinity may affect the quality of the sound received by the hearing aid.

## Maintenance

Clean using a soft cloth. Do not pour water onto the appliance and do not use any type of chemical product.

Cleaning must be carried out either with the apparatus powered off (= disconnected from the bus) or after activating the keypad cleaning procedure (see the relative paragraph in the user manual).

## Warnings for the user

Do not open or tamper with the appliance.

In the event of faults, contact specialized personnel.

## Installation

**Important:** The device should be installed at a height of approximately 160 cm off the floor, taking care not to expose it to direct sources of light so as to avoid annoying glare on the surface of the LCD screen.

**Note:** Fig. 1 shows the recommended installation distances, unless otherwise specified by current regulations.

1. Secure the plate to the wall, with metal bracket, in box: circular 2M (Vimar V71701), 3M (Vimar V71303, V71703) horizontal/vertical and square British standard.
2. Wire the terminal block (Fig. 5).
3. Terminate the video signal (Fig. 6)
4. Install the video entryphone as follows: position the video entryphone on the plate keeping it slightly raised. While keeping the front panel pressed, apply a light downward pressure until it clicks into place.
5. Should you need to remove the monitor you need to apply a light pressure on the lever (Fig. 3) and lift it (upwards) to release the video entryphone from the frame.

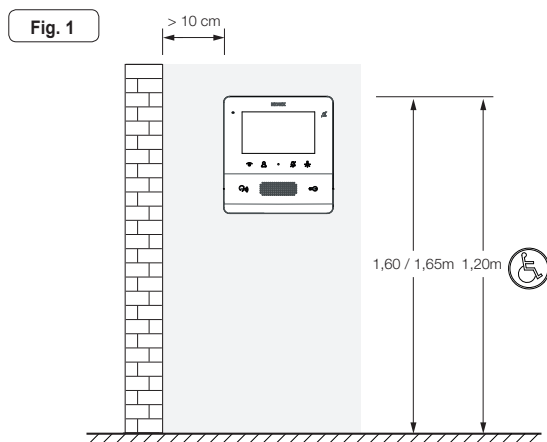

Fig. 2

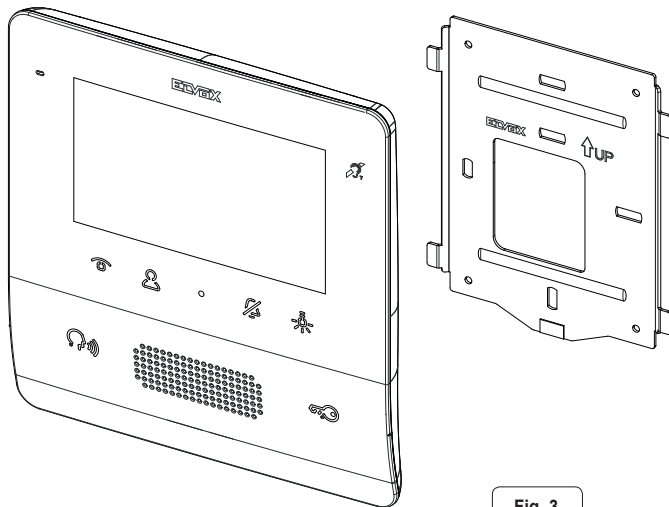
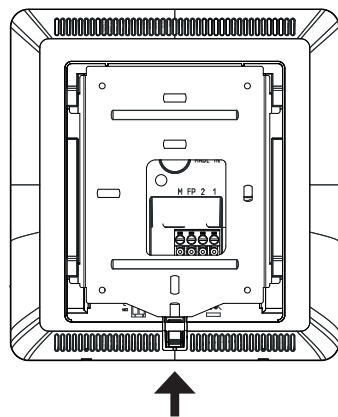

Fig. 3



## Connections

On the rear there is a terminal board for:

- connection of the Due Fili Plus bus
- The local Landing Call input. The maximum connection distance is 10 m. When suitably programmed using SaveProg, this input can be used for the Alert function. See the relative paragraph.

Connection terminal block	
Terminals	Function
1, 2	DUE FILI PLUS digital bus.
FP	Landing Call button input (terminal M reference).
M	Reference earth

Note: Art. 7559 does not have terminals for an additional power supply. For this reason, if the section of the Due Fili bus in which the internal unit is located is busy with another call/conversation, or another 7559 or 40505 is switched on for any reason, regardless of its operating status, it will not be possible to switch on a second 7559 or 40505 and a tone will sound to warn the user. The only possible action is to operate the lock, stair light or auxiliary function using the dedicated buttons, provided they are not configured for other functions; the Alert function can be used as described in relative paragraph.

Fig. 5

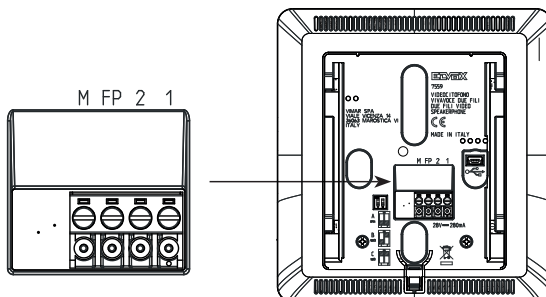

## Video Termination

### Select DIP switch to terminate the video signal

- A) if the BUS cable enters terminals 1, 2 and continues to another internal unit.
- B) when a BUS cable with a characteristic impedance of 100 Ohms (Elvox 732I or 732H cable) enters terminals 1, 2 and the riser stops in the internal unit
- C) when a BUS cable with characteristic impedance of 50 Ohms (Cat. 5 or Cat. 6 twisted pair cable) enters terminals 1, 2 and the riser stops in the internal unit.

Fig. 6

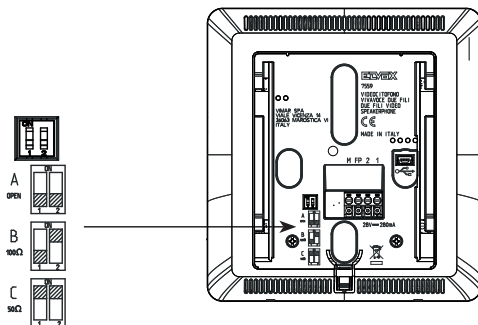

## Connection

### Connecting the internal unit in the in/out configuration

In/out wiring diagram

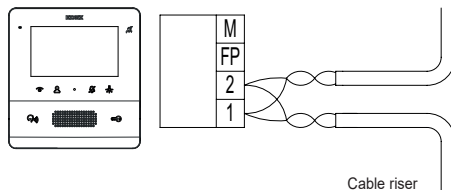
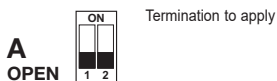

### Connecting the internal unit in terminal configuration

Wiring diagram with cable terminating in the internal unit

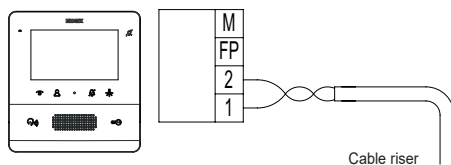
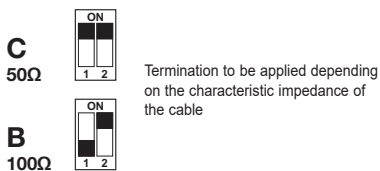

### Variant for connecting the landing or alert button

Connecting the FP/M terminal

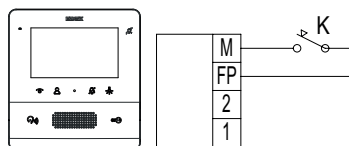



## Key functions

In the subsequent sections of this document the touch keys are designated as shown in the figure below:

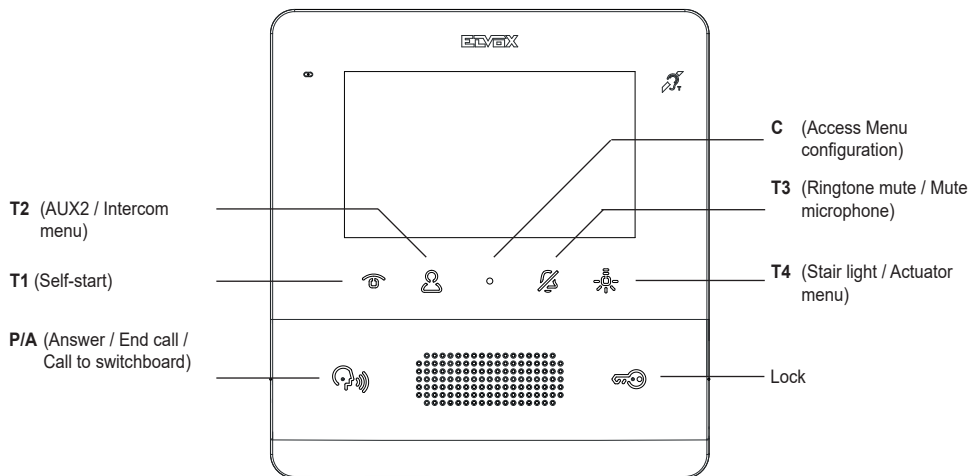





At rest, none of the buttons perform the touch function, but must be pressed for longer (around 0.4 s): this prevents the accidental activation of commands. Unless specifically disabled, the recognition notice is given by acoustic signalling.

Keys **T1..T4** have two operating contexts:

- Actuations
- Intercom

In the *Actuations* context, keys **T1..T4** have a default (when not programmed), as indicated in the following figure, along with the default icons: They can be programmed from the installer menu or using SaveProg.

KEY	ICON	MEANING
<b>T1</b>		Self-start
<b>T2</b>		Aux 2
<b>T3</b>		F2 last outdoor unit
<b>T4</b>		Aux 1

In the *Intercom* context keys **T1..T4** have no default configuration. They can be programmed from the installer menu or using SaveProg.

**T2** (P7 for SaveProg) is not configured by default and controls the second relay (Aux2). If it is configure via SaveProg, it runs the programmed function. **In standby**, if only one of the *Intercom* context programmings are run, whatever the programming of **T2**, 7559 will directly run the programmed intercom call. If two or more *Intercom* context programmings are run, then the *Intercom* context menu is shown so that the user can decide which call to make.

The following table summarises and clarifies the **T2** operation. It refers to the SaveProg programming, as this does not depend on the context.



CONFIGURATION	STANDBY	CALL / CONVERSATION / SELF-START / ACTUATIONS CONTEXT
None of P3..P6 configured. P7 not configured.	Aux2	
None of P3..P6 configured. P7 configured.	Programmed function in P7	
Only one of P3..P6 (Pn) configured, the others not. P7 not configured.	Intercom call or alert programmed in Pn	Aux2
Only one of P3..P6 (Pn) configured, the others not. P7 configured.	Intercom call or alert programmed in Pn	Programmed function in P7
At least two of P3..P6 configured. P7 not configured.	The <i>Intercom</i> context is shown	Aux2
At least two of P3..P6 configured. P7 configured.	The <i>Intercom</i> context is shown	Programmed function in P7



**T3** has the function of *ringtone mute* / mute microphone. The associated LED will operate also as an indicator for:

- *User absent* (the internal unit rejects the call from an outdoor unit and consequently the call is unsuccessful). In this case the LED flashes at intervals of 0.1 s on and 0.9 s off.
- *Ringtone disabled* (the internal unit does not ring for calls from the outdoor unit, but otherwise functions normally). In this case the LED is on steady.

The LED is essential when the display is switched off.

The **C** key cannot be programmed and its function is context-dependent.

The **P/A**  key is used to answer or close a call / conversation. In standby it calls the porter switchboard, if the management with switchboard is active. Moreover, the LED associated to the **P/A** key  remains on and switches off briefly for 1, 2, 3 or 4 times for each cycle according to the number of calls received and but not answered for any reason. If there are any missed calls, press the **P/A**  key for 2 s to reset the call counter. The same can be done by re-activating the ringtone, after self-start, or after answering a call.

By default, the **LOCK**  key controls the lock of the last outdoor unit to make a call or the outdoor unit for which self-start procedure was performed. It can only be programmed using SaveProg. The LED associated with the **LOCK**  key indicates door open status of the system, essential when the display is switched off, even if the same key is programmed for another function. In some states (e.g. conversation) the  icon also appears in the top right-hand side of the screen.

In standby mode, the screen is completely switched off. (In the method described above), by activating any one of the keys **T1..T4** and **LOCK**  by default the function is performed without switching on the display unless the function has to do so in order to be performed, such as self-start.

Starting with 7559 in default, the **T4** key enables the first relay in the Due Fili system. It is usually indicated as *stair light* or *Aux1*. When one or more of the other three keys (**T1..T3**) in the *Actuations* context is configured, the **T4** key does not act directly but opens the complete menu of keys **T1..T4** in the *Actuations* context.



*Actuations context*

For configuration see the relative paragraph. In the previous figure **T1** was re-configured as an icon and was associated to a function other than default. When pressed, keys **T1..T4** run the explicitly set or default function. The icons shown on **T2..T4** are the default settings, unless otherwise selected by the installer. When they are pressed the timeout (15 s) starts again, and no other controls can be given. The **C**  key forces immediate exit.

The same menu can be recalled during:

- Self-start
- Calls
- Conversation with outdoor unit, another internal unit or the porter switchboard

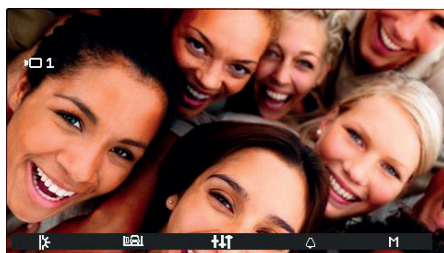

In these cases, if more than one functions of **T1..T3** in the *Actuations context* has been reconfigured, the icon corresponding to **T4** changes as shown in the following figure:



*Re-configured actuations*

Press **T4** to view the same menu with the internal unit in standby, the difference being that key **C**  now leads to the menu which appeared before pressing **T4**. Hereafter refer always to the default programming.

## First power up

7559 is supplied without ID. On switching on the display by touching the keypad, the only action possible is to assign main  1 or secondary  2 internal unit as the ID:

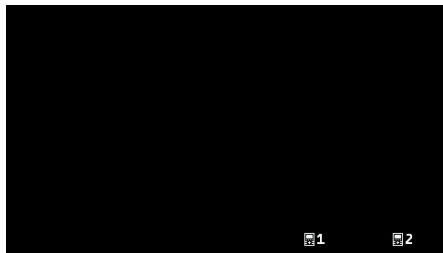



First power up

On choosing one of the two, the internal unit requests ID assignment from the Master outdoor unit and the functions of the keys change as follows:



Initialisation in progress

T1  now serves to cancel a request, T3  and T4  serve respectively to reduce and increase the speaker volume. On completion of the ID assignment procedure, the number assigned will appear at the top of the display:

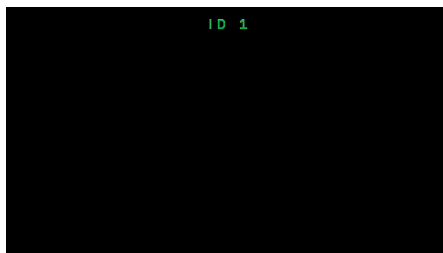

Assigning ID

---

## **After ID assignment**

Once the ID has been assigned, the internal unit 7559 has no graphic menu in standby, but only in the call, conversation, self-start or configuration states.

## User configuration

Press key **C** to access the user configuration menu. In all the menus, navigation is circular, i.e. scrolling down past the last option in any menu takes you back to the first option.

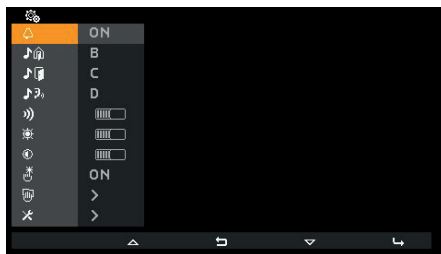





User configuration menu

Each item is selected with T4 ↵.

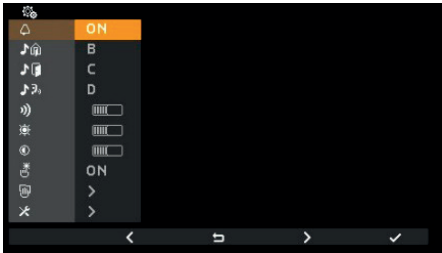

## Ringtone mute

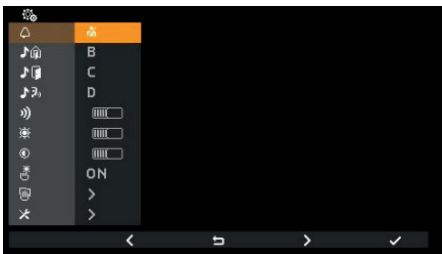
Use **<** and **>** to enable/disable the ringtone of the internal unit, **for calls from outdoor unit**, as follows:

ICON	IMAGE	CONDUCT
ON		Ringtone on
		Ringtone mute. The internal unit does not ring, but otherwise functions normally.
		User away. The internal unit does not ring and does not switch on. With configuration via SaveProg (flag ACK. Grp. Excl. S) it is possible to ring secondary internal units, otherwise the call from the outdoor unit is rejected and unsuccessful

*Ringtone mute* is the same function assigned with **T3** to an internal unit in standby or call mode.

**The ringtone mute function does not apply to calls received from an internal unit or porter switchboard.**

Press **T4**  to confirm, **C**  to cancel without saving.

**Note: in the remaining part of this manual, it is assumed that the functions of T1, T4 and C are understood.**

Default: ringtone enabled.

## Select call melody from outdoor unit

Use **<** and **>** to select one of the 10 available melodies (identified by letters A to J) to use as a ringtone for calls from the outdoor unit. The internal unit plays back the selected ringtone.

Default: melody B.



Select melody for call from outdoor unit

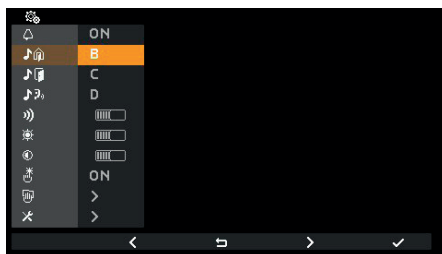

Confirm melody for call from outdoor unit



## Select landing call melody 🎵📞

Use **<** and **>** to select one of the 10 available melodies (identified by letters A to J) to use as a ringtone for calls from the landing, whether in local contact FP-M or Art. 6120. The internal unit plays back the selected ringtone.

Default: melody C.

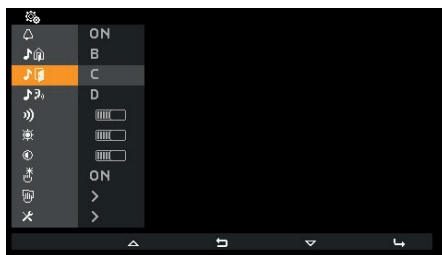

Select melody for call from landing

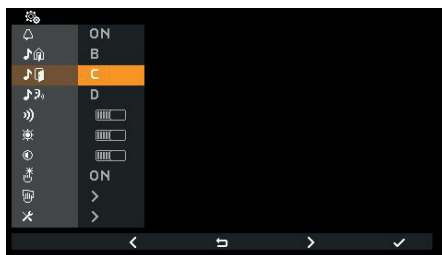

Confirm melody for call from landing

## Select call melody from internal unit or switchboard 🎵🔊

Use **<** and **>** to select one of the 10 available melodies (identified by letters A to J) to use as a ringtone for calls from an internal unit or switchboard. The internal unit plays back the selected ringtone.

Default: melody D.

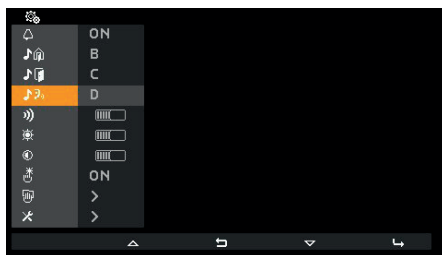

Select call melody from internal unit or switchboard

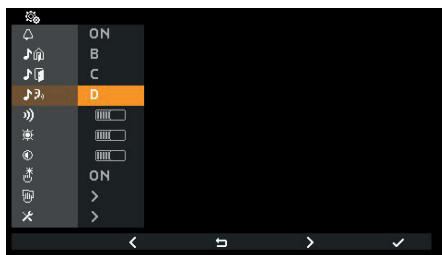

Confirm call melody from internal unit or switchboard

## Ringtone volume control )))

Use **-** and **+** to increase/decrease the ringtone volume, which is indicated by the horizontal bar.

NOTE: the set level is used for all ringtone types (calls from the outdoor unit, landing, indoor unit or switchboard).

Default: level 5.

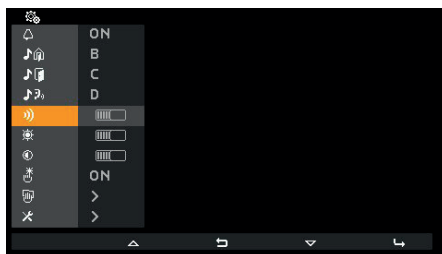

Select ringtone volume control

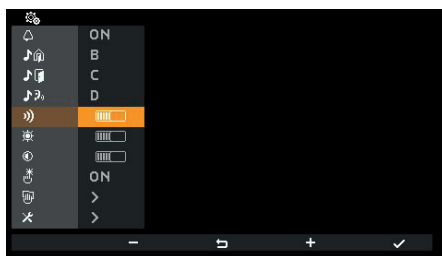

Ringtone volume control

## Brightness control

Use **-** and **+** to increase / decrease the brightness of the video signal from an outdoor unit, the level of which is indicated by the horizontal bar. The internal unit automatically requests the Master outdoor unit to perform a self-start procedure so that the user can see the effect of the brightness control.

NOTE: the level set is used for all outdoor units. Self-start follows the time set in the outdoor unit and is not renewed with any variations in controls.

Default: level 5.

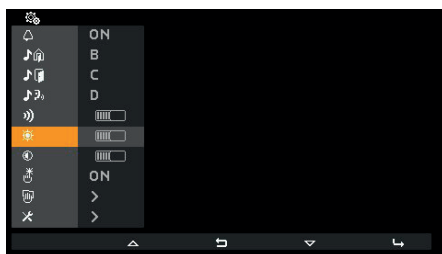

Select brightness control

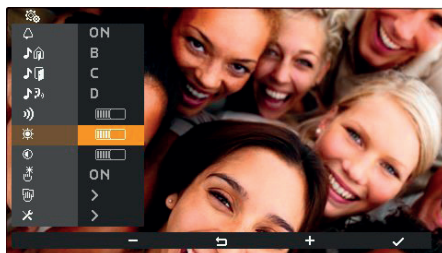

Brightness control

## Contrast control

Use **-** and **+** to increase / decrease the contrast of the video signal from an outdoor unit, which is indicated by the horizontal bar. The internal unit automatically requests the Master external unit to perform a self-start procedure so that the user can see the effect of the contrast control.

NOTE: the level set is used for all outdoor units. Self-start follows the time set in the outdoor unit and is not renewed with any variations in controls.

Default: level 5.

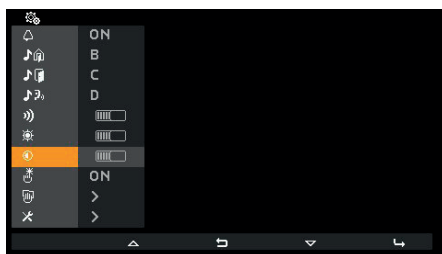

Select contrast control

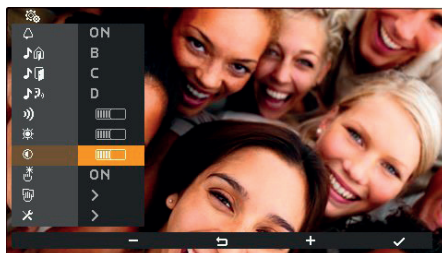

Contrast control

## Key tones

Use the keys < and > to enable/disable the tone produced whenever a key is touched (keystroke feedback).

Default: enabled



Key tone

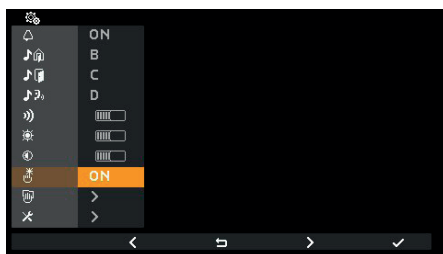

Selecting the key tone

## Keyboard cleaning

Activates the keyboard cleaning function:

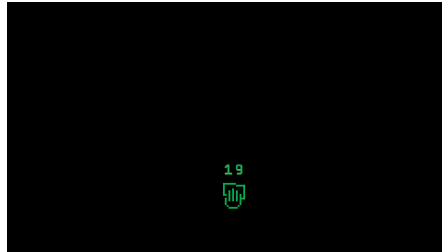





Keypad cleaning activation







The *keyboard cleaning* function lasts 20 seconds and this time period cannot be extended by pressing the keys, which remain disabled until the keyboard cleaning procedure is completed.

## Installer configuration ✕

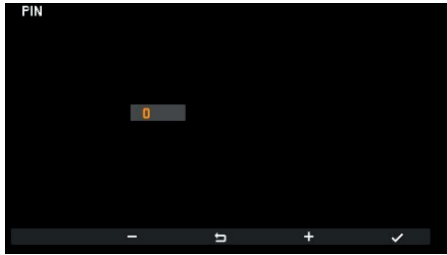
To access the installer menu, you must enter the 3-digit code (PIN). The (default) PIN is 100, but this can be edited as described below. The PIN is entered using the following keys:

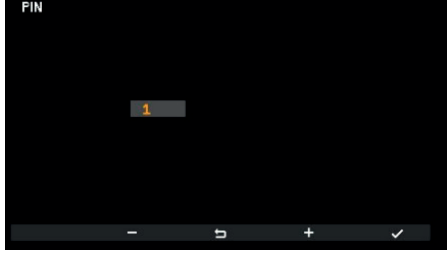
- **T2**  to change the digit highlighted in colour in the sequence 0 – 9 – 8 ... – 2 – 1 – 0 ...
- **C**  to cancel the last digit, provided that the cursor is on the second or third digit, otherwise use  to return to the user configuration menu.
- **T3**  to change the digit highlighted in colour in the sequence 0 – 1 – 2 ... – 8 – 9 – 0 ...
- **T4**  to confirm the selected digit, and after the third digit, if the PIN entered is correct, to access the installer configuration procedure. If the PIN is not correct, you are returned to the user configuration menu.

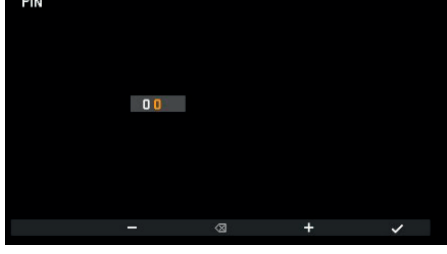
Note: once the correct PIN has been entered and you have returned to the user menu, it will not be necessary to enter the PIN again to access the installer menu, until the internal unit returns to standby mode.

	Touch 
	Touch 
	Touch 





Entering the PIN

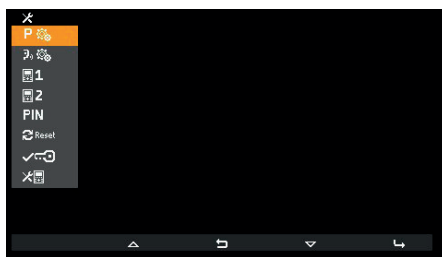

Installer menu

## Selection of key icons in the *Actuations* context



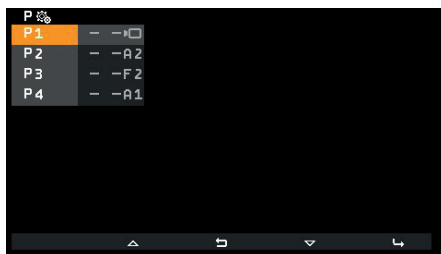

With the option  you can change the icons that appear above the keys in the *Actuations* context and relative associated actuations.

The default setting is blank:







Selection of key icons in the *Actuations* context

For each key, in the right-hand side of the menu there is a selection and actuation icon, respectively. If, as in this case, no icon has yet been selected, the menu shows  and in the *Actuations* context the default icons are used, respectively:

KEY	ICON
T1	
T2	
T3	
T4	

The keys have default actions which are shown in the furthest column to the right. To distinguish the default settings which have not been selected by the installer, the indication is preceded by . The defaults are:

KEY	ICON	MEANING
T1		Self-start
T2		Aux 2
T3		F2 last outdoor unit
T4		Aux 1

When assigning icons starting from the default setting, touching T4  opens the following menu:

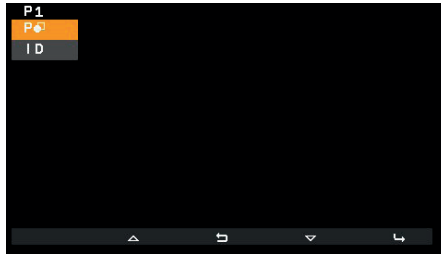

- **P2** to select the icon
- **ID** to select the actuation to associate

## Select the icon

The item  opens a list of selectable icons:

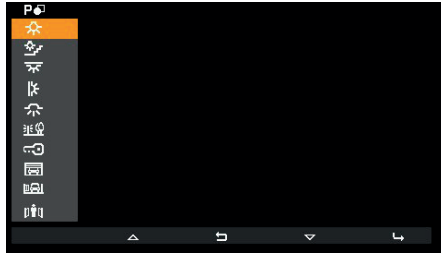

Selection of key icons

## Select the actuations | D

The item **| D** opens a list of selectable actuations:



Selecting the actuations

There are 6 default actuations. These are the first 4 relays and F1 / F2 on the last outdoor unit the internal unit communicated with or was called from.

If previously the installer has changed the function associated to this, it is present in the list of selectable actuations, highlighted with the current value:



Using SaveProg it is possible to draft the list of selectable actuations in order to include:

- 16 relays
- locks on 15 outdoor units
- Lock of the last outdoor unit
- F1 for 15 divided outdoor units, depending on the state of the flag "F1/F2 1-8" in SaveProg, in:
  - o Outdoor units 1 to 8
  - o Outdoor units 9 to 15
- F1 of the last outdoor unit
- F2 for 15 divided outdoor units, depending on the state of the flag "F1/F2 1-8" in SaveProg, in:
  - o Outdoor units 1 to 8
  - o Outdoor units 9 to 15
- F2 of the last outdoor unit

When the list has a number of items that fill 3 or more configuration pages (this happens with at least 18 elements), in **T1** the **...** icon appears and is used to move quickly from one page to another. The following figures show the situation with all permitted actuations:

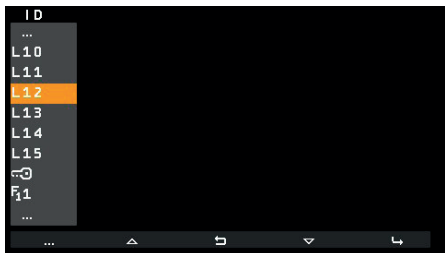
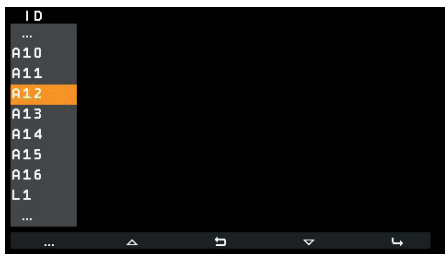

In any case, ... at the top of the list indicates that before there are other elements. ... at the bottom it indicates that after there are other elements.

## Deleting xP

If an icon or an actuation has already been assigned, an option will be added to the specific menu that allows you to cancel the assigned icon and replace it with the default icon. The actuation is also taken to default.

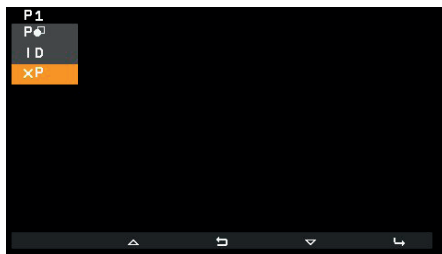

This operation must be confirmed:



Confirm icon cancellation

To change an icon or actuation, you do not need to cancel it first, just simply replace it with a new icon.

## Intercom

With the option  you can change the IDs of internal units or porter switchboards to be used in the *Intercom* context. The default setting is blank:

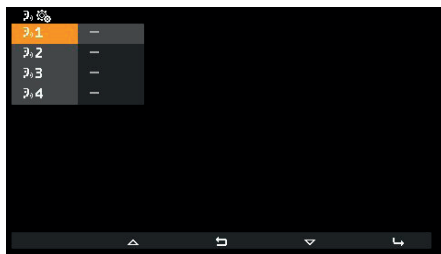



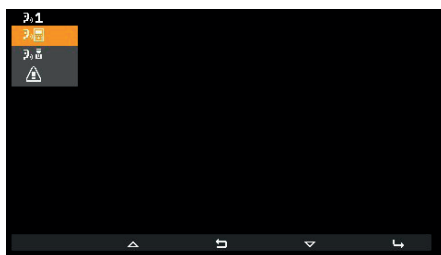

Intercom menu

Each line corresponds to one of the four keys in the *Intercom* context. On selecting one of these four options, a sub menu opens:



Selection of intercom type

The three options that appear are:

-  to associate an internal unit with the selected position.
-  to associate a porter switchboard with the selected position.
-  to associate the Alert function with the selected position.
-  to cancel the association with the selected position (visible only if the position is programmed).



## Association of an internal unit

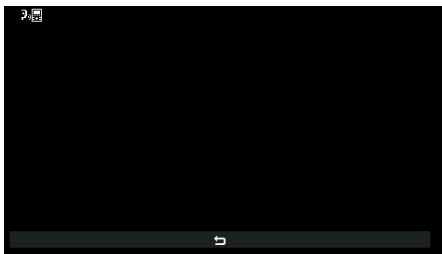

Awaiting association of the internal unit to be called

In this condition, on the internal unit that is to be called, press a key that can be identified unequivocally. It is advisable to use a key that controls opening of a lock, but you can also use a key that operates a relay or controls one of the F1 or F2 outputs of an external unit. If the internal unit that is to be called has a handset, it is advisable to use the lock with the handset replaced.

Once the association has been made, the basic menu of the *Intercom* context will appear as follows (the internal unit to be called is number 4):

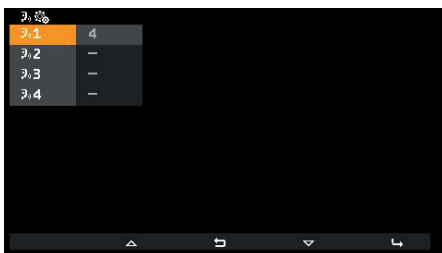

## Association of a porter switchboard

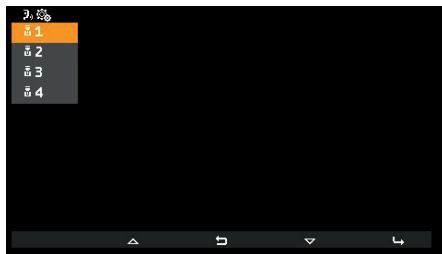

Selection of the switchboard to be called

Select the porter switchboard you wish to assign to the previously selected key in the *Intercom* context and confirm. The basic menu of the *Intercom* context will appear as follows:

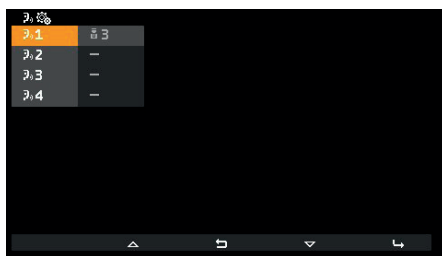

## Association of the Alert function

On confirming the function, the Alert function is immediately assigned to the previously selected key:

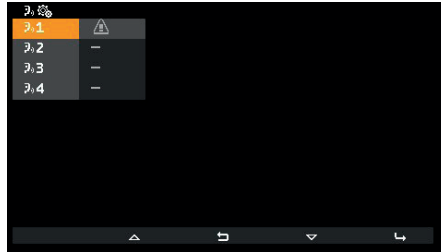

## Canceling an association

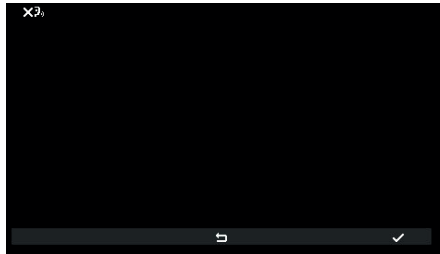

Awaiting confirmation of intercom cancellation

Confirm or cancel removal of the association between previously selected key in the *Intercom* context.

## Assignment of main 1 and secondary ID 2

For descriptions of these procedures, refer to the beginning of the paragraph *First power up*.

## Changing the PIN FIN

To change the PIN, follow the same procedure as that used to enter it to access the installer configuration menu. The following example shows how to set the PIN to 123:

	Touch ✓
	Touch +
	Touch ✓
	Touch + 2 times

 <p>The screenshot shows a black screen with the word 'PIN' in the top left corner. In the center, the numbers '1 2' are displayed in a grey box. At the bottom, there is a control bar with a minus sign, a camera icon, a plus sign, and a checkmark icon.</p>	<p>Touch ✓</p>
 <p>The screenshot shows a black screen with the word 'PIN' in the top left corner. In the center, the numbers '1 2 0' are displayed in a grey box. At the bottom, there is a control bar with a minus sign, a camera icon, a plus sign, and a checkmark icon.</p>	<p>Touch + 3 times</p>
 <p>The screenshot shows a black screen with the word 'PIN' in the top left corner. In the center, the numbers '1 2 3' are displayed in a grey box. At the bottom, there is a control bar with a minus sign, a camera icon, a plus sign, and a checkmark icon.</p>	<p>Touch ✓</p>

The PIN has now been changed to 123.

## Reset factory configuration

This procedure allows you to cancel any settings and programming of the internal unit and to restore it to the initial default condition. The system asks for confirmation that you wish to proceed with the reset:

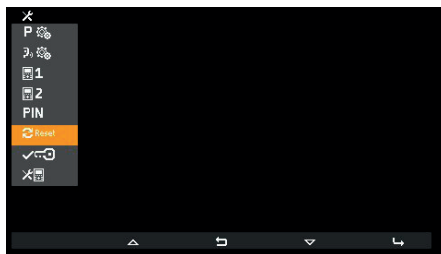

Selection of Reset factory configuration



Awaiting confirmation of Reset factory configuration

From this moment, the internal unit is in the *First power up* **condition**.



## Enabling Professional Firm

This procedure run by the installer is used subsequently by the user to enable or disable the Professional Firm function. For a description of the service refer to the relative paragraph.



Selecting Professional Firm

The item relating to the current state of the service enabling is highlighted. In this case it is disabled:

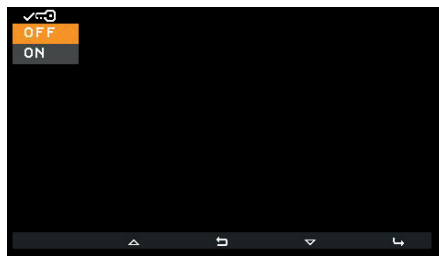

Selecting the Professional Firm activation

Select the required state and confirm.

**Note:** disabling leads also to de-activation.

## System information

From this menu, useful information can be obtained for Vimar customer service (SAC / TSX), including ID, Firmware version, etc.:

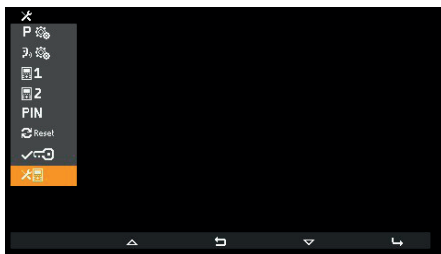

System information

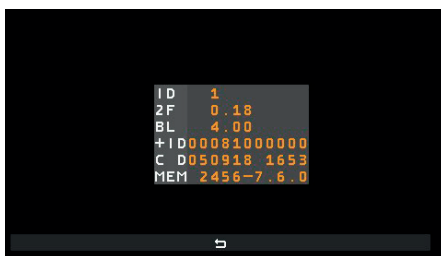

Information display

- The information reported, from the top downwards, is as follows:
- ID of the internal unit
- FW version
- Bootloader version
- UID
- FW compilation date and time
- Available memory – FreeRTOS version used

## Programming with SaveProg

SaveProg manages Art. 7559 from version 3.7.0.0 onwards. The correspondence between the keys P1..P8 in SaveProg and keys T1..T4 in the two operating contexts is the following:

KEY	INTERCOM	ACTUATIONS
T1	P3	P1
T2	P4	P7
T3	P5	P8
T4	P6	P2

The LOCK  key corresponds to P0.

## Call to internal unit (outgoing)

**Note:** before connecting the audio channels with any other device, the internal unit Art. 7559 determines the best possible communication parameters. During this stage, which lasts approximately 1 second, a waiting tone is transmitted to the user.

To make a call to another internal unit, at least one call must be programmed as described above must be configured in the installer menu. If via SaveProg, the call to porter switchboard has been enabled, this is done in standby by pressing the **P/A**  key.

The figure below shows the situation when all the keys are programmed. This *Intercom* context is accessed by pressing **T2** in standby when at least two intercom calls are configured. With just one configuration, the action will be direct and the call will be sent as soon as **T2** is pressed.

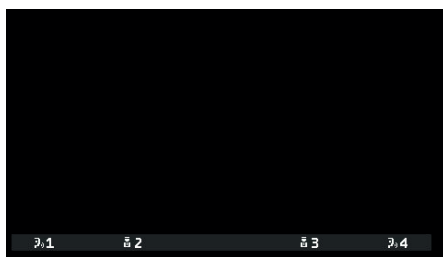

Intercom Context

In the example, **T1** and **T4** make a call to an internal unit, **T2** and **T3** towards two specific porter switchboards.

The call is initiated by touching one of the above keys. Before the call is answered, the display changes to the following:

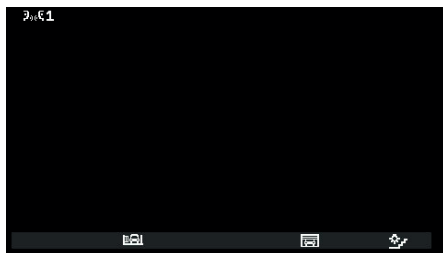



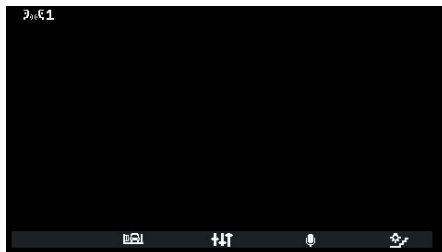

Pending answer

The icons at the top left of the display indicate that a call is being made to the internal unit programmed as **T1**. While waiting for an answer, you can press **T2**, **T3** and **T4**. On receiving an answer, the display changes to:



Microphone on

The central key also becomes active, now  and T3 changes meaning.  is used to enter the *Audio only settings* context. T3 has the mute microphone function. The icon indicates the state, so  means that the microphone is on and  that it is off.

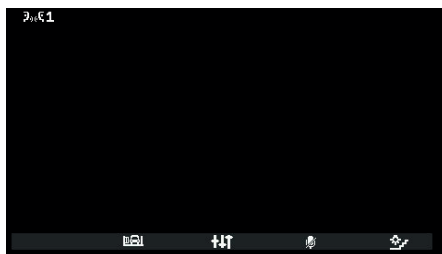



Microphone off

The *Audio only settings* context is used only to control the speaker volume.



Intercom volume control

The T1  and T2  keys turn grey respectively when the minimum and maximum levels are reached.

The centre key, now , allows you to return to the previous context.

The conversation can be ended with the P/A  key or by the internal unit to which the call was made using the appropriate procedure.

## Call from internal unit (incoming)

On receiving a call from another internal unit, the display appears like this:

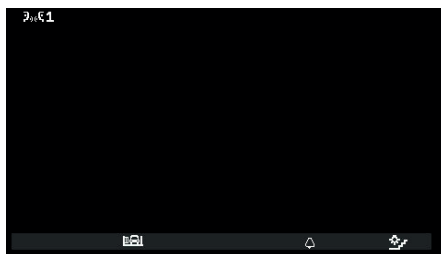

Incoming call from internal unit belonging to the *Intercom* context

The number at the top left indicates the position of the caller in the list of keys in the *Intercom* context. If the caller is not present in the list, no number will be displayed.

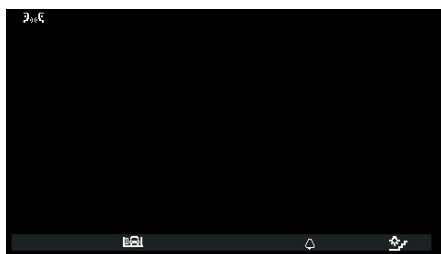

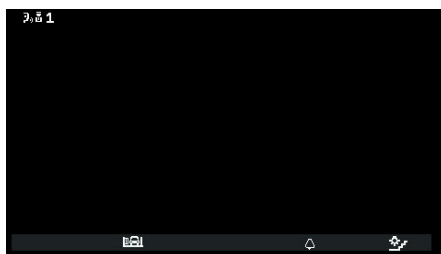

Incoming call from internal unit not belonging to the *Intercom* context

If the caller is a switchboard, different icons appear at the top left of the display:





Call from switchboard 1

For incoming intercom calls, it is not possible to mute the ringtone before a call is received. It is only possible to mute the ringtone for the current call using **T3**. Once muted, the ringtone cannot be switched back on during the current call, so the icon disappears. The icon indicates the states, so only the  symbol appears.

The call is answered using the **P/A**  key, after which the situation is the same as with an outgoing call.

The conversation can be ended using the **P/A**  key or by the calling internal unit using the appropriate procedure.

Note: before answering the LED associated to the **P/A**  button stops flashing, if it was flashing previously to indicate missed calls. Answering the current call also causes the flashing to stop once the internal unit returns to stand-by. If the current call is not answered either, at the end of the call the **P/A**  Led flashing counter increases, if within the limit, by one unit.

## Switchboard scenarios

If the unit either making or receiving the call is a porter switchboard, there are other possible scenarios. For example, the switchboard operator could connect an internal unit to another internal unit, to an outdoor unit or to a second porter switchboard.

If the switchboard operator already has the other internal unit, external unit or switchboard on hold, he/she will connect it directly.

Alternatively, he/she could put this internal unit on hold while carrying out the necessary operations to call the other party. The switchboard operator can only connect an external unit to the internal unit if the external unit is already on hold:



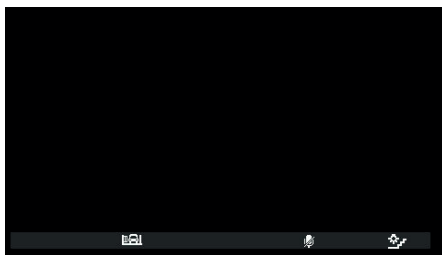

Internal unit connected to external unit

During the wait, the internal unit will emit a specific tone. The internal unit can also cancel the wait by putting the internal unit in standby mode using the **PIA**  key.



Internal unit during the wait

During the wait, the microphone is obviously muted and will remain as such also when the switchboard operator connects the internal unit to the other party, which means that, once connected, it will be necessary to use **T3**  to re-enable the microphone. Alternatively, you can also use **T3**  before the new connection is made. In this case the microphone will already be enabled. Given that it is not possible to know beforehand the exact moment at which the switchboard operator will connect the internal unit to the other party, this strategy has been chosen in order to ensure that the other party hears nothing unless at the explicit request of the party waiting.



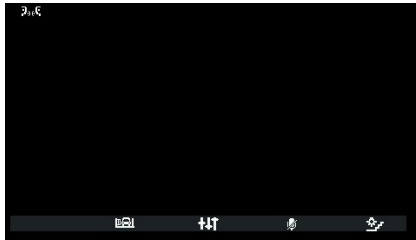

Internal unit connected to another internal unit



Internal unit connected to a porter switchboard

The conversation will proceed as if held directly between the internal unit and the other party.

## Call from outdoor unit (incoming)

On receipt of a call from an external unit, the display can appear in two different ways, depending on whether the call is coming from an audio only or from an audio/video external unit:



Call from outdoor unit (incoming), audio



Call from outdoor unit (incoming), video

Note: the display of internal unit Art. 7559 switches on when receiving a call from an external unit to display the video signal of the external unit in accordance with its own programming, as indicated in the table below.

CALL FROM VIDEO EXTERNAL UNIT	FLAG 1 IN SAVEPROG (MONITOR ON)	RESULT
Direct	ON	Switches on
	NOT ACTIVE	Does not switch on
Indirect (belongs to a group with only one secondary unit)	ON	Switches on
	NOT ACTIVE	Does not switch on
Indirect (belongs to a group with at least two secondary units)	ON	Does not switch on
	NOT ACTIVE	Does not switch on

Note: the secondary internal units indicated in the previous table are exclusively Arts. 40505 or 7559. They also ring at a reduced, fixed volume (level 4 out of 10).

On answering, the display switches on to show the video from the external unit calling.

**T3**, with the icon , is used to silence the ringtone for the call in progress and at the same time sets the ringtone mute function. Once muted, the ringtone cannot be switched back on during the current call, so the icon disappears.

Before answering, if the display is showing the video signal from the outdoor unit, you can adjust the brightness by accessing the *Video only settings* with .



Video adjustments

If the call originates from an audio external unit, it will not be possible to make any adjustments.

The **T3**  and **T4**  keys turn grey respectively when the minimum and maximum levels are reached.

The centre key, now , allows you to return to the previous context.

Before answering, whatever condition the internal unit is in, it is possible to use the *Actuations* context or the **LOCK**  key, unless programmed for another function.



To answer the call from an outdoor unit, use the **P/A**  key.



Answering an audio call



Answering a video call

As in a conversation with an internal unit, **T3** has the function of muting the microphone. The icon indicates the state, so  means that the microphone is on and  that it is off.

After answering, it is possible to use the *Actuations* context or the **LOCK**  key, unless programmed for another

function.

During the conversation, the **+††** key serves to enter the *Audio only settings* context if the call originates from an audio outdoor unit or *Audio and video settings* context if the call originates from an audio/video outdoor unit.

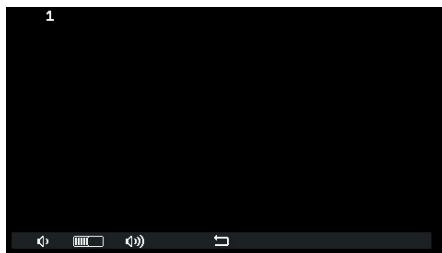

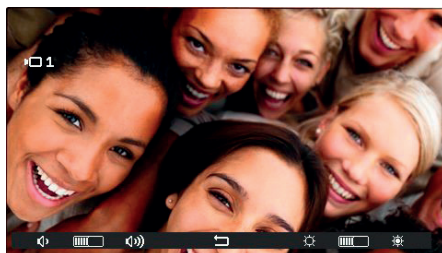

Audio settings



Audio/video settings

The **T1** and **T3**, **T2** and **T4** keys turn grey respectively when the minimum and maximum levels are reached.

The conversation can be ended using the **P/A**  key or by the calling outdoor unit in the appropriate manner.

Note: before answering the LED associated to the **P/A**  button stops flashing, if it was flashing previously to indicate missed calls. Answering the current call also causes the flashing to stop once the internal unit returns to stand-by. If the current call is not answered either, at the end of the call the **P/A**  Led flashing counter increases, if within the limit, by one unit.

## Self-start

The self-starting of an outdoor unit is performed with the audio signal relayed from the outdoor unit to the internal unit activated so that from the internal unit, the user can hear but not be heard:



Self-start activation



As can be seen from the icon on **T3**, the microphone of the internal unit is muted. It can be enabled or muted again by touching the **T3** key. The **P/A**  key interrupts conversation regardless of whether the microphone is enabled or muted.

During self-start, it is possible to use the *Activations* context or the **LOCK**  key, unless programmed for another function.

The **↑↑** key gives access to the *Audio only settings* context if the call originates from an audio outdoor unit or *Audio and video settings* context if the call originates from an audio/video outdoor unit.

The conversation can be ended using the **P/A**  key or by the outdoor unit in the appropriate manner.

## Pan – Zoom



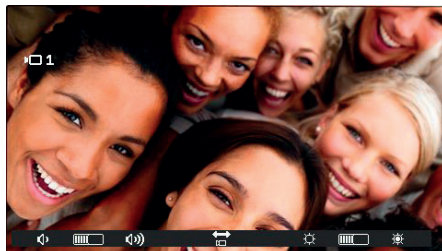

Combined with a Pixel outdoor unit with appropriate characteristics (Art. 41004 and 41005, with FW version supporting the function), internal unit Art. 7559 shows in the central key in the *Video only settings* context the  icon instead of . The icon does not appear if the outdoor unit does not have the required characteristics. If possible, it appears both for calls from outdoor units even before answering, and in self-start.





Pressing the central key the  icon goes to the *Pan / Zoom* context.

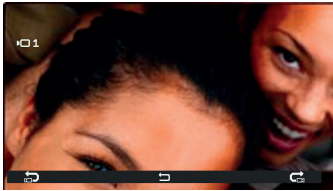

In the *Pan / Zoom* context it is possible to instruct the Pixel outdoor unit to show one of the five zones, in the order indicated in the following table, with full-screen zoom:

ORDER	EXAMPLE	ORDER	EXAMPLE
1 COMPLETE IMAGE		5 BOTTOM RIGHT CORNER	
2 CENTRAL AREA		6 BOTTOM LEFT CORNER	
3 TOP LEFT CORNER		7 COMPLETE IMAGE	
4 TOP RIGHT CORNER			

The **T1** key with the  icon moves upwards in this table (the images change anti-clockwise). The **T4** key with the  icon moves downwards (the images change clockwise).

The central key, now , allows you to return to the *Actuations* context.

## Professional Firm Function

The *Professional Firm* function is used to automatically activate the lock on receiving a call from any outdoor unit in the system. The *Professional Firm* function in Art. 7559 is basic and has no time bands. It must have been enabled via the installer menu, or from SaveProg, and can be activated or deactivated by the user. By default the *Professional Firm* function is both disabled and deactivated.

## Professional Firm Operation

The activation or deactivation of the Professional Firm service by the user are done in two ways, where enabled in the installed menu

1) With a long touch of the **LOCK**  key. In particular, the function is the following, depending on the length of the touch. If less than 5 s, the duration is calculated when the key is released:

DURATION	EFFECT
From 0.4 to 2 s	Lock actuation
From 2.1 to 5 s	None, to avoid false manoeuvres
After 5 s	Activation or deactivation of <i>Professional Firm</i>



The *dead time* between 2 and 5 seconds is needed to avoid false lock opening manoeuvres and at the same time allows the actuation even if the touch remains for a short time.

The activated service is indicated by the internal unit speaker giving of a high frequency tone for 0.2 s. At the same time the LED associated to the **LOCK**  key flashes and remains on for 0.2 s every 4 s.

The deactivated service is indicated by the internal unit speaker giving of a lower frequency tone for 0.2 s. At the same time the LED associated to the **LOCK**  key goes out.

If this occurs while a door open message is indicated, the LED flashes inversely, i.e. it remains off for 0.2 s every 4 s.

2) Alternatively, having entered the user configuration menu, it is possible to activate / deactivate the service using **T1**  which appears only once enabled by the installer.

ICON	PROFESSIONAL FIRM
	Disable
	On

The enabling switches at each touch.

Once the *Professional Firm* function has been enabled and activated, when receiving a **direct** call from an outdoor unit, after 1 s, the configured internal unit will send the calling outdoor unit the lock actuation message.

Note: the function is available only for **direct** calls, i.e. for the master unit. There is no relation with the fact that the internal unit has been assigned a main or secondary ID. They are two separate concepts.

If the lock has been activated, when the outdoor unit receives the *ringtone end* message the internal unit automatically terminates the call. It is possible to avoid the automatic termination of the call by excluding the SaveProg flag called *Autom.Lock End* which is normally selected automatically when the Professional Firm function is enabled. If the SaveProg flag called *End Quick. Call* is active, the call is ended immediately after the lock actuation is confirmed, and not on receipt of the *ringtone end*.

The following table summarises what stated above:



FLAGS ACTIVE				EVENT	RESULT
Enabling Professional Firm	Activating Professional Firm	Automatic Lock End	Quick Call End		
NO	X	X	X	Call from outdoor unit to internal unit	None
YES	NO	X	X	Call from outdoor unit to internal unit	None
YES	YES	NO (edited in SaveProg)	X	Call from outdoor unit to internal unit	Sending after 1 s following the lock command
				Confirm lock actuation and subsequent ringtone end	None
YES	YES	YES	NO	Call from outdoor unit to internal unit	Sending after 1 s following the lock command
				Confirm lock actuation and subsequent ringtone end	End call
YES	YES	YES	YES	Call from outdoor unit to internal unit	Sending after 1 s following the lock command
				Confirm lock actuation	End call

## Alert

Internal unit Art. 7559, together with porter switchboard Art. 40510, creates a system that can send an alert to the switchboard operator even when the Due Fili bus is busy.

To activate this service:

1. Programme via SaveProg or the internal unit one of the keys **T1..T4** in the *Intercom* context to enable the Alert function. The icon displayed is . More than one key can be programmed to perform the same function, but the results will be indistinguishable.
2. Enter the *Intercom* context.
3. Touch one of the previously programmed keys.
4. The internal unit sends the alert.
5. It is possible to use the pair of terminals FP-M as a remote input for the Alert function. Their use does not preclude the configuration of **T1..T4**, and vice versa, but the landing call function will be lost (terminals FP-M). The FP-M operating mode is selected using SaveProg. Closing the terminals FP-M has the same operational effect as that described below for the **T1..T4** keys.

This is what happens then:

6. The internal unit waits to receive the alert from the switchboard. In the meantime, the chosen signalling is sent to the user according to the table below. On receipt of the message, the switchboard emits a double beep and displays a red envelope icon to alert the operator.
7. If it does not receive a replay, the internal unit resends the message every 10 s. After 5 attempts with no reply the internal unit stops sending the messages.
8. When an internal unit receives confirmation of the receipt of the message by the switchboard, the chosen signalling is sent to the user according to the table below. Normally the time between the sending of the request and confirmation of reception is less than a second.
9. Until the switchboard calls the internal unit to service the request, the internal unit resends the message every 120 s. At each message, the switchboard emits two beeps and increases count of messages received. The counter can be viewed by opening the list of alerts in the switchboard. The sending of messages never terminates. It continues until the end of the service described in the next point, unless the switchboard is powered off or removed from the system, in which case the internal unit, after 5 unsuccessful attempts starting from the first timeout of 120 s, will return to standby mode and the LED on the LOCK key will stop flashing.
10. If the switchboard operator calls the internal unit from the list of warnings, and only from this, a message is sent to the internal unit via the Due Fili bus to end the Alert procedure so the relative signal is no longer sent to the user.

If the bus is engaged in another conversation or by another 7559 or 40505 already powered on, the *Intercom* context is inaccessible. If at least one of the **T1..T4** keys is programmed as the Alert function, then LEDs relative to this function will flash for 10 s while waiting for the user to touch any one of these keys. No other keys are enabled and the display is not switched on. Once the function has been initiated, all the LEDs of the Alert function will switch off and the internal unit will return to standby mode; in any case, the internal unit will return to standby after 10 s.

Note: if the internal unit is switched off, when it is switched back on again the function starts again from the beginning.

## Alert Configuration

Use SaveProg to select some of the characteristics of the Alert function:

1. Enabling
  - a. Disabled (default)
  - b. Enabled
2. Polarity state active
  - a. Contact normally open (default)
  - b. Contact normally closed
3. Activation delay
  - a. 0.1 s (default)
  - b. 0.5 s
  - c. 1 s
  - d. 2 s
4. Signalling mode
  - a. None
  - b. LED associated to the **T2** button (default)
  - c. Sound

According to the selected signalling type, apart from the first, the timer is as follows:

STATE	LED TIMER	SOUND TIMER
The internal unit waits to receive the alert from the switchboard	Flashing with a cycle of 0.5 s on / 0.5 s off	A 2 KHz tone for 0.2 s
The internal unit has received confirmation of the receipt of the message from the switchboard	Flashing with a cycle of 0.1 s on / 0.1 s off	A 1 KHz tone for 0.1 s

---

## **FW updates**

SaveProg manages Art. 7559 from version 3.7.0.0 onwards.

---

## Driver for PC

The drivers are the same as for the other device in the TAB family. The first time a device is connected to a USB port, the PC must associate the drivers to the peripheral device even if a TAB device has already been associated. The internal unit is identified in SaveProg as ELVOX\_P129A.





CE

49401253A0\_MI\_EN 00 1901



**VIMAR**

Viale Vicenza 14  
36063 Marostica VI - Italy  
[www.vimar.com](http://www.vimar.com)