

RQLB1 90-M | metric thread

Connectors FLEXAquick for ROHRflex corrugated plastic tubings

Plastic connector, quick-type, bend 90°, metric outer thread, integrated, snap-in sleeve, conically sealed

Temperature: -40°C ... +120°C

Material: PA plastics

IP class [acc. to EN 60529]: IP 65

CHARACTERISTICS:

- Properties: resistant against oil and benzine
- widely resistant to acids and solvents
- free of silicone, cadmium, halogen

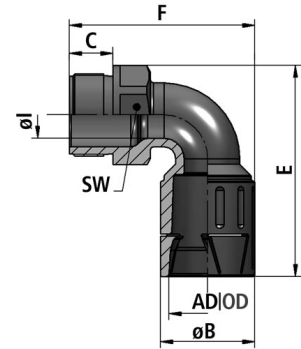

APPLICATIONS:

- Application: machine and plant constructions / automotive / shipbuilding / automation / electrical installations



FLEXA No.	Colour	OD [mm]	Thread type	Ø I [mm]	Ø B [mm]	C [mm]	E [mm]	F [mm]	WS [mm]	Weight [kg/100]	PU [pcs.]
15117013216	Black	13,0	M16 x 1,5	10,0	20,0	11,0	47,0	42,5	18	1,100	50
15117015220	Black	15,8	M20 x 1,5	12,5	24,0	11,0	52,0	46,5	22	1,500	50
15117018220	Black	18,5	M20 x 1,5	14,0	26,0	13,0	55,5	51,5	27	1,700	50
15117018225	Black	18,5	M25 x 1,5	14,0	26,0	13,0	55,5	51,5	27	1,700	50
15117021220	Black	21,2	M20 x 1,5	14,0	29,5	13,0	61,8	54,2	27	2,100	50
15117021225	Black	21,2	M25 x 1,5	14,0	29,5	13,0	61,8	54,2	27	2,100	50
15117028225	Black	28,5	M25 x 1,5	18,8	36,0	13,0	71,5	66,7	35	3,200	25
15117028232	Black	28,5	M32 x 1,5	18,8	36,0	13,0	71,5	66,7	35	3,200	25
15117034232	Black	34,5	M32 x 1,5	26,0	44,0	15,0	85,5	71,0	43	4,800	10
15117034240	Black	34,5	M40 x 1,5	26,0	44,0	15,0	85,5	71,0	43	4,800	10
15117042240	Black	42,5	M40 x 1,5	35,0	52,0	16,0	104,5	81,5	53	7,400	10
15117042250	Black	42,5	M50 x 1,5	35,0	52,0	16,0	104,5	81,5	53	7,400	10
15117054250	Black	54,5	M50 x 1,5	45,0	64,0	16,0	122,0	94,8	66	10,600	5
15117054263	Black	54,5	M63 x 1,5	45,0	64,0	16,0	122,0	94,8	66	10,600	5

Recommendations for any areas of applications, products, or product combinations are issued to the best of FLEXA's knowledge and experience. The user is requested to check applicability of FLEXA products to specific applications and purposes prior to the use of the particular products. All documentation, illustrations, and charts published are subject to copyright and must not be copied, changed, used, or modified. Technical drawings, certificates, authorizations, and results by the FLEXA lab will be provided upon request. FLEXA will not be held liable for typographical or other errors and incorrect drawings. Technical modifications are subject to change without prior notice.