



CASSETTA STAGNA IP66 CON PASSACAVI INIETTATI

Co-moulded watertight enclosures



CARATTERISTICHE TECNICHE

Technical feature

Dimensioni interne (mm) <i>Internal dimensions</i>	243x190x90
Passacavi costampati <i>Co-Molded cable glands</i>	12
Grado di protezione <i>Protection degree</i>	IP66
Grado IK <i>IK degree</i>	IK07
Materiale <i>Material</i>	Tecnopolimero (Halogen Free) <i>Tecnopolymer</i>
Materiale passacavi iniettati <i>Material injected glands</i>	Elastomero Termoplastico (Halogen Free) <i>Thermoplastic elastomer</i>
Resistenza al calore <i>Heat resistance</i>	Termopressione con biglia 70°C <i>Thermopressure with marble at 70°C</i>
Resistenza della Cassetta al fuoco <i>Resistance to fire</i>	Glow wire 650°C
Temperatura di installazione <i>Installation temperature</i>	Max= +60°C / min.= -15°C
Normativa di riferimento <i>Reference requirements</i>	EN 60670

DOCUMENTAZIONE ALLEGATA

attached documentation

Tabella dimensionale <i>Dimensional table</i>	010_PG_TD
--	-----------

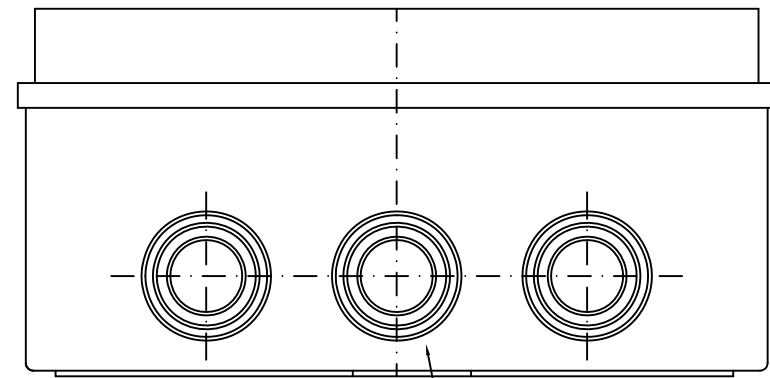
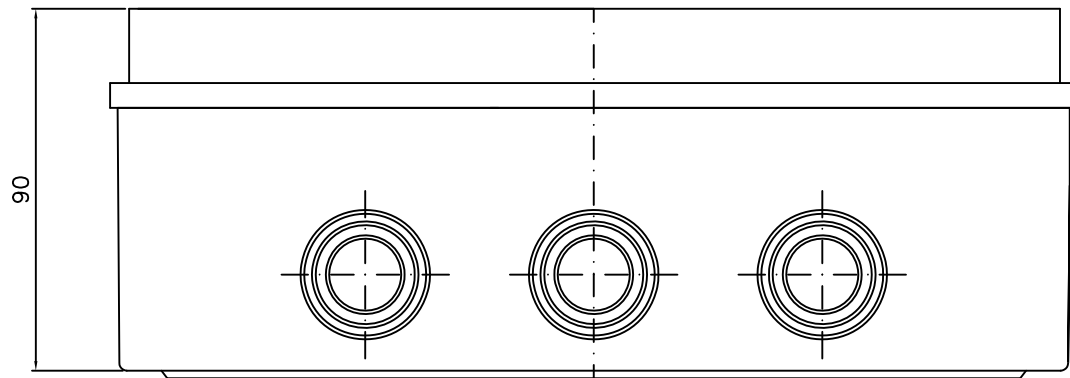

MAX ø37

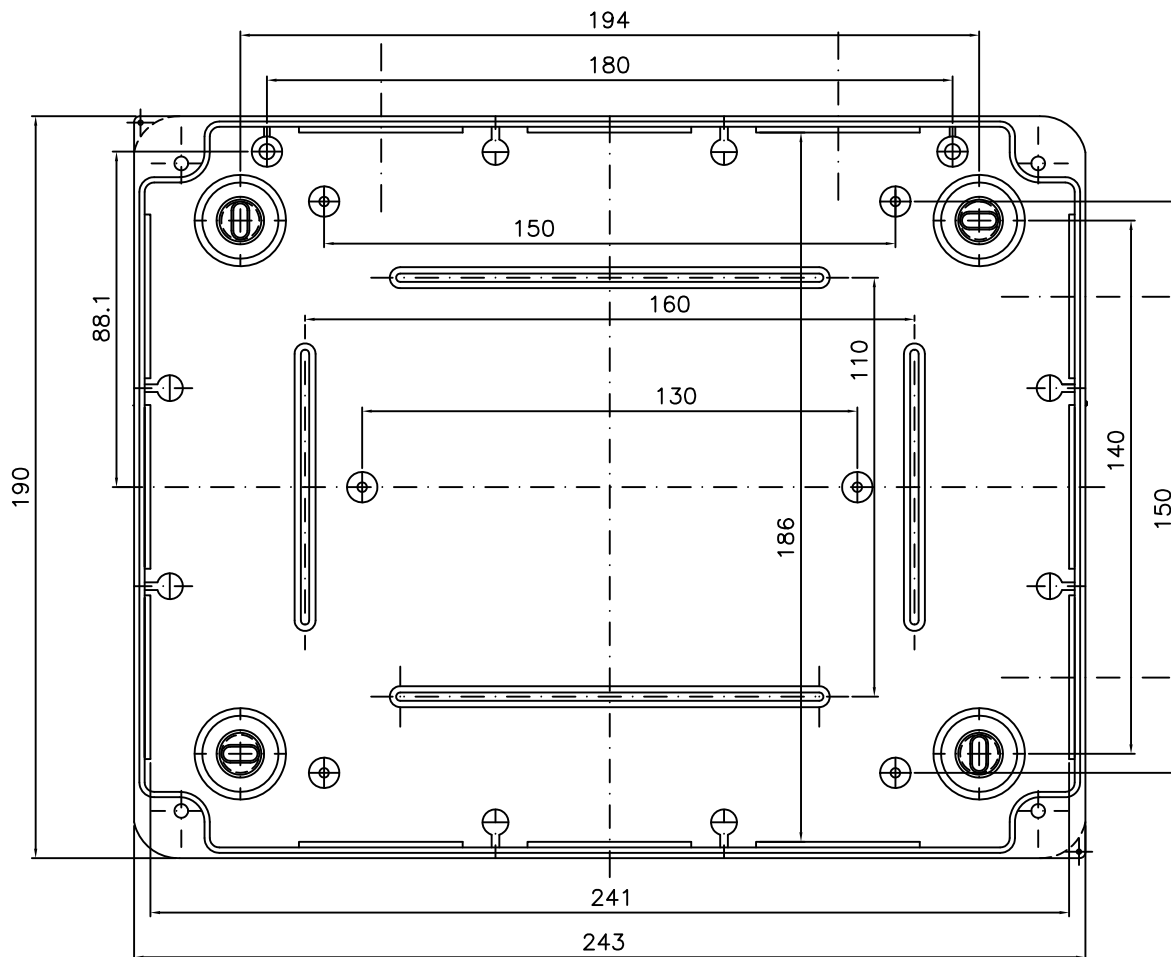

BOITE ETANCHE IP66 – PASSECABLE INJECTES

IP66 ADAPTABLE BOX – INJECTED GLANDS

Cassetta Stagna IP66 con Passacavi Iniettati

010.PG
010.PG.K
010.PG.VO

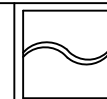

Marlanvil

Tel: 02-83.45.19.11 Fax: 02-83.45.19.99

-San Ferdinando di Puglia (BT)

-Milano via Sasseti, 17 E-mail: info@marlanvil.it

23/03/04