

Technical Data Sheet

CODE 11291

VORT HRI 200 PHANTOM B.P.

Ceiling-mounting residential heat recovery
units



Certifications



TECHNICAL AND PERFORMANCE DATA

Absorbed Current max (A)	1,0	Delivery max (m ³ /h)	206
Absorbed Power max (W)	102	Pressure max (mmH ₂ O)	43,5
Frequency (Hz)	50	Pressure max (Pa)	426
Max ambient temperature for continuous operation (°C)	40	Sound power level - radiated L _w [dB(A)]	43,1
Nominal Diameter (mm)	125	Sound power level exhaust inlet L _w [dB(A)]	36,5
Voltage (V)	230	Sound power level supply outlet L _w [dB(A)]	43,3
Weight (Kg)	27	Sound pressure level air extraction L _p in free field [dB (A)] 3m - max speed	16,0
Delivery max (l/s)	57,2	Sound pressure level air supply L _p in free filed [dB (A)] 3m - max speed	22,8
		Sound pressure level radiated L _p in free filed [dB (A)] 3m - max speed	22,6

DIMENSIONS

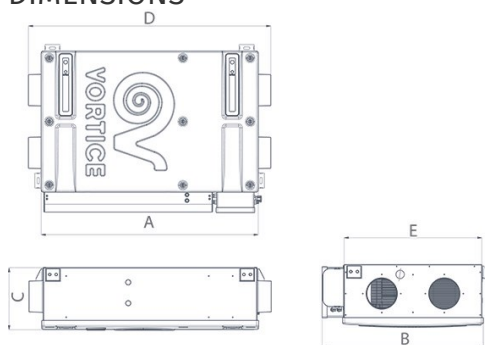

Diametro ϕ (mm)	125
Size A (mm)	868
Size B (mm)	643
Size C (mm)	248
Size D (mm)	963,5
Size E (mm)	551

PER INFORMAZIONI:

Servizio al Cliente: tel +39 02 90699395 premendo 1 dopo messaggio registrato (consulenza su prodotti e impianti)

Pre & Post Vendita: fax +39 02 90699302

Email prevendita: prevendita@vortice-italy.com

Technical Data Sheet

CODE 11291

VORT HRI 200 PHANTOM B.P.



Ceiling-mounting residential heat recovery units

DESCRIPTION

- Zinc-coated pressed steel enclosure; interior lined with sound-absorbent and fire-resistant material (DIN 13501)
- Nominal diameter for duct connections: 125 mm.
- EC brushless motors with shafts turning in ball bearings, coupled directly to centrifugal impellers; 3 speeds selectable at the moment of installation.
- Air flow settable between 75 m³/h and 200 m³/h.
- Ultra high efficiency cross-flow type heat recovery unit manufactured

- in plastic (polyethylene).
- 100% by-pass, automatically operated.
- Automatically activated system designed to prevent icing of the heat exchanger.
- 2 x F5 filter (F7 optional)
- Electronic control system
- Tie-bolts for suspended installation supplied as standard

CURVES

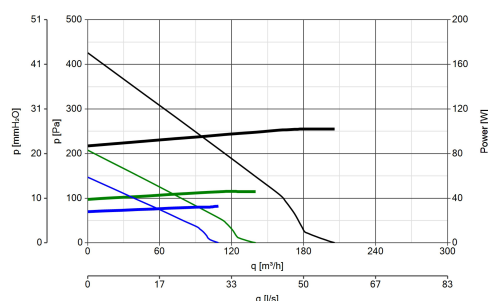

ACCESSORIES



C PIR
Code 12998



**DCW 250
D.150(BATTERIA
FREDDA)**
Code 24146



**PANNELLO
INSTALLATORE
SKP10**
Code 22629

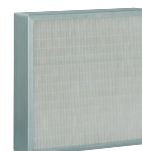

**FTR F7
228X224X24**
Code 22625

PER INFORMAZIONI:

Servizio al Cliente: tel +39 02 90699395 premendo 1 dopo messaggio registrato (consulenza su prodotti e impianti)
Pre & Post Vendita: fax +39 02 90699302
Email prevendita: prevendita@vortice-italy.com