

Technical Data Sheet

CODE 12106

VORT HR 350 AVEL

Wall-mounting residential heat recovery unit



Certifications

TECHNICAL AND PERFORMANCE DATA

Absorbed Current max (A)	1,4	Weight (Kg)	23
Absorbed Power max (W)	165	Delivery max (l/s)	100
Filter class	F5	Delivery max (m ³ /h)	350
Frequency (Hz)	50	Maximum thermal efficiency (%)	90,5
Insulation Class	I°	Pressure max (mmH2O)	90
IP	X2	Pressure max (Pa)	880
Max ambient temperature for continuous operation (°C)	25	Sound power level - radiated Lw [dB(A)]	57,3
Max Temperature of Exhaust Air (Continuous Operation)	40	Sound power level exhaust inlet Lw [dB(A)]	43,6
Min ambient temperature for continuous operation (°C)	0	Sound power level supply outlet Lw [dB(A)]	60,2
Nominal Diameter (mm)	150	Sound pressure level air extraction Lp [dB (A)] 3m - max speed	23,1
Voltage (V)	230	Sound pressure level air supply Lp [dB (A)] 3m - max speed	39,7
		Sound pressure level radiated Lp [dB (A)] 3m - max speed	36,8

DIMENSIONS

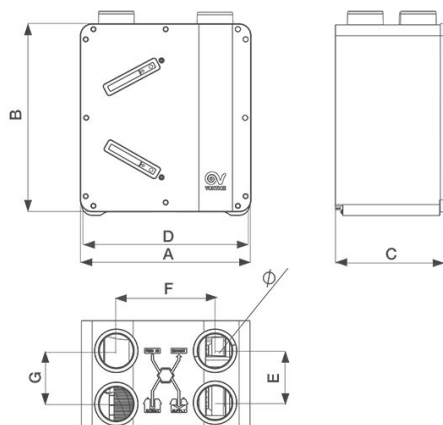

Diametro ϕ (mm)	150
Size A (mm)	712
Size B (mm)	845
Size C (mm)	455
Size D (mm)	700
Size E (mm)	215
Size F (mm)	410
Size G (mm)	220

PER INFORMAZIONI:

Servizio al Cliente: tel +39 02 90699395 premendo 1 dopo messaggio registrato (consulenza su prodotti e impianti)

Pre & Post Vendita: fax +39 02 90699302

Email prevendita: prevendita@vortice-italy.com

Technical Data Sheet

CODE 12106

VORT HR 350 AVEL

Wall-mounting residential heat recovery unit



DESCRIPTION

- Plastic (PPE) fire-resistant enclosure (DIN EN 13501). Brackets for wall-mounted installation supplied as standard.
- Front panel made of plastic resin, integrating covers for filters direct access.
- Round duct connection ports, nominal diameter 150 mm.
- 2 EC (brushless) motors, external rotor, with shaft turning in ball bearings to grant a "maintenance free" functioning, each coupled to a backward curved centrifugal impeller; 2 speeds, independently adjustable at the installation.
- High efficiency counter-flow heat exchanger in PS resin.
- Automatic frost-protection to prevent icing on the heat exchanger.
- Automatic, 100% filtered, mechanic by-pass, granting people comfort in the rooms in mid-season or when the outside temperature does not require the action of the heat exchanger.
- Wired control panel with LCD display, which allows:
 - to switch on / off the unit;
 - the first set-up;
 - to set the speed;
 - to set the weekly timer;
 - to show time and room temperature;
 - to monitor the correct product operation (any faults are shown on the display);
 - to show the filters status.
 - 2 M5 filters (F7 filter for air supply duct available as optional), easy access for periodic maintenance.
 - Condense water tray with discharge pipes.
 - Possibility of connection to environmental external sensors (available as optional), for automatic functioning control.

ACCESSORIES



C TEMP
Code 12992



C SMOKE
Code 12993



C HCS
Code 12994



C PIR
Code 12998

PER INFORMAZIONI:

Servizio al Cliente: tel +39 02 90699395 premendo 1 dopo messaggio registrato (consulenza su prodotti e impianti)
Pre & Post Vendita: fax +39 02 90699302
Email prevendita: prevendita@vortice-italy.com