

Technical Data Sheet

CODE 17007

VORTICE LINEO 200 Q V0

In-line mixed flow fans



Certifications



TECHNICAL AND PERFORMANCE DATA

Absorbed power 1st speed (W)	45	Delivery 1st speed (l/s)	194,4
Frequency (Hz)	50	Delivery 1st speed (m ³ /h)	700
Insulation Class	II ⁰	Max delivery at max speed (l/s)	263,9
IP	44	Max delivery at max speed (m ³ /h)	950
Max ambient temperature for continuous operation (°C)	60	Pressure - 1st speed (mmH2O)	13
Max. absorbed Current at max. speed (A)	0,37	Pressure - 1st speed (Pa)	127,5
Max. absorbed Current at min. speed (A)	0,22	Pressure max - max speed (mmH2O)	29
Max. absorbed power at max speed (W)	75	Pressure max - max speed (Pa)	284,5
Nominal Diameter (mm)	200	RPM max	2740
Voltage (V)	220-240	RPM min	1780
Weight (Kg)	4,3	Sound pressure level Lp [dB (A)] 3m - max speed	49,0
		Sound pressure level Lp [dB (A)] 3m - min speed	39,6

DIMENSIONS

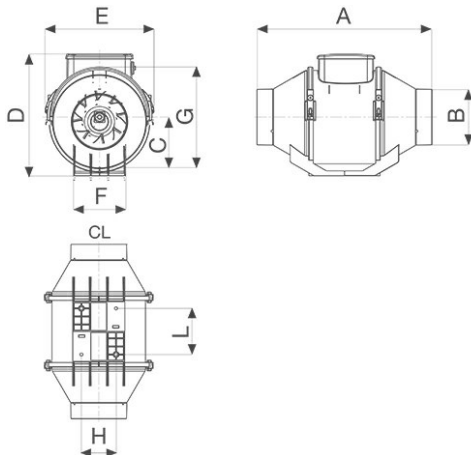

Size A (mm)	234,5
Size B (mm)	260,5
Size C (mm)	300
Size D (mm)	196
Size E (mm)	125,5
Size F (mm)	235
Size G (mm)	140
Size H (mm)	94
Size L (mm)	100
Size M (mm)	6

PER INFORMAZIONI:

Servizio al Cliente: tel +39 02 90699395 premendo 1 dopo messaggio registrato (consulenza su prodotti e impianti)

Pre & Post Vendita: fax +39 02 90699302

Email prevendita: prevendita@vortice-italy.com

Technical Data Sheet

CODE 17007

VORTICE LINEO 200 Q V0

In-line mixed flow fans



DESCRIPTION

- Material: self-extinguishing plastic resin (self-extinguishing capability V0)
- Nominal diameter 200 mm.
- 2 speed AC motor with thermal overload cutout and shaft turning in ball bearings, coupled to mixed flow axial-centrifugal impeller.
- Minimum air flow 700 m³/h
- Maximum air flow: 950 m³/h
- IMQ SAFETY and IMQ PERFORMANCE certifications
- Vortice speed controllers.

CURVES

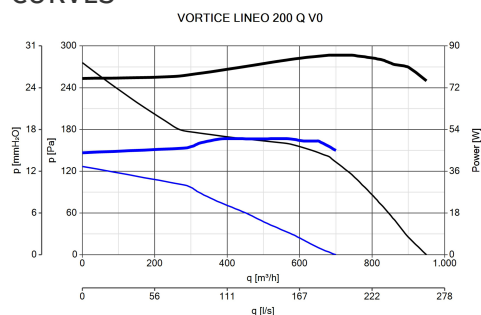

ACCESSORIES



C PIR
Code 12998



C TIMER
Code 12999



KIT SCB
(TRASF.E.C.)
Code 22481

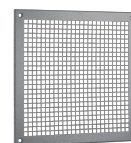

TRA 250
(TELAIO CON
RETE ANTINF.)
Code 51150

PER INFORMAZIONI:

Servizio al Cliente: tel +39 02 90699395 premendo 1 dopo messaggio registrato (consulenza su prodotti e impianti)
Pre & Post Vendita: fax +39 02 90699302
Email prevendita: prevendita@vortice-italy.com