

# Technical Data Sheet

CODE 17156

## LINEO 250 V0 ES

Energy saving mixed flow extractor fans



### Certifications



### TECHNICAL AND PERFORMANCE DATA

Frequency (Hz)	50	Delivery 1st speed (l/s)	24
Insulation Class	II°	Delivery 1st speed (m³/h)	85
IP	44	Max delivery at max speed (l/s)	306
Max ambient temperature for continuous operation (°C)	50	Max delivery at max speed (m³/h)	1100
Nominal Current at max speed (A)	1	Pressure - 1st speed (mmH2O)	0,7
Nominal Current at min speed (A)	0,05	Pressure - 1st speed (Pa)	7
Nominal Diameter (mm)	250	Pressure max - max speed (mmH2O)	60
Nominal Power at max speed (W)	124	Pressure max - max speed (Pa)	588
Nominal Power at min speed (W)	3	RPM max	3000
Voltage (V)	220-240	RPM min	300
Weight (Kg)	5,3	Sound pressure level Lp in free field [dB(A)] 3 m max speed	57,3

### DIMENSIONS

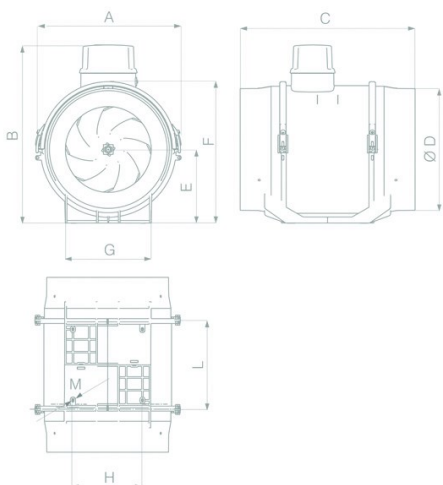

Size A (mm)	300
Size B (mm)	350
Size C (mm)	385
Size D (mm)	247
Size E (mm)	152,5
Size F (mm)	292
Size G (mm)	176,5
Size H (mm)	140
Size L (mm)	145
Size M (mm)	8

#### PER INFORMAZIONI:

Servizio al Cliente: tel +39 02 90699395 premendo 1 dopo messaggio registrato (consulenza su prodotti e impianti)

Pre & Post Vendita: fax +39 02 90699302

Email prevendita: [prevendita@vortice-italy.com](mailto:prevendita@vortice-italy.com)

# Technical Data Sheet

CODE 17156

## LINEO 250 V0 ES

Energy saving mixed flow extractor fans



### DESCRIPTION

- Material: self-extinguishing plastic resin (self-extinguishing capability V0)
- Nominal diameter: 250 mm.
- High efficiency EC (brushless) motor, thermally insulated, with shaft on ball bearings, coupled to a mixed flow impeller.
- Cylindrical motor support equipped with straightens flow and integrating the wiring connection box with airtight lid.
- Possibility of connection to remote sensors.
- A dedicated dip-switch allows to choice:
  - o 2 speed product functioning, settable during the installation and adjustable through optional two-speed switch,
  - o 1 speed product functioning, adjustable through 0-10V signal potentiometer (supplied as optional).

### CURVES

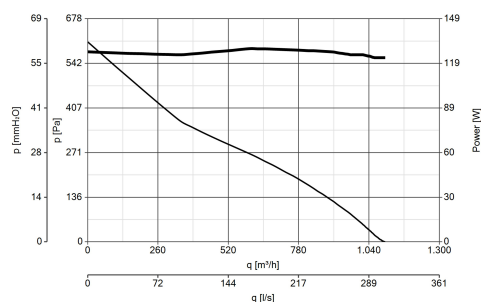

### ACCESSORIES



**POT-IT**  
Code 12826



**POT**  
Code 12828



**C PIR**  
Code 12998



**C TIMER**  
Code 12999

#### PER INFORMAZIONI:

Servizio al Cliente: tel +39 02 90699395 premendo 1 dopo messaggio registrato (consulenza su prodotti e impianti)  
Pre & Post Vendita: fax +39 02 90699302  
Email prevendita: prevendita@vortice-italy.com