

# Technical Data Sheet

CODE 45380

## VORT NRG 600 EC

Heat recovery units equipped with static heat exchangers



## Certifications



## TECHNICAL AND PERFORMANCE DATA

Filter class for extract air	G4	Nominal Diameter (mm)	250
Filter class for supply air	F7	Number of Phases (Ph)	1
Frequency (Hz)	50	Protection current	2,8
Max ambient temperature for continuous operation (°C)	60	Voltage (V)	230
Motor Class	B	Weight (Kg)	120
Motor IP protection	54	Delivery max (m <sup>3</sup> /h)	650
Motor Power (W)	169X2	Sound power level - radiated Lw [dB(A)]	57

## DIMENSIONS

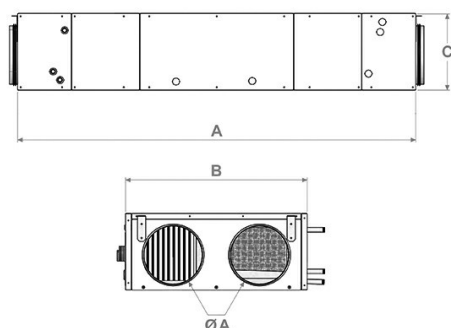

Size A (mm)	1700
Size B (mm)	780
Size C (mm)	330
Size D (mm)	150
Size E (mm)	370
Size F1 (mm)	795
Size F2 (mm)	486
Size F3 (mm)	422
Size G (mm)	150
Size G1 (mm)	50
Size G2 (mm)	145
Size J (mm)	180
Size K (mm)	645
Size M (mm)	640
Size M1 (mm)	259
Size M2 (mm)	1168
Size M3 (mm)	273
Size T (mm)	1/2"
Size T1 (mm)	1/2"
Vents diameter Ø A (mm)	250

### PER INFORMAZIONI:

Servizio al Cliente: tel +39 02 90699395 premendo 1 dopo messaggio registrato (consulenza su prodotti e impianti)

Pre & Post Vendita: fax +39 02 90699302

Email prevendita: [prevendita@vortice-italy.com](mailto:prevendita@vortice-italy.com)

# Technical Data Sheet

CODE 45380

## VORT NRG 600 EC

Heat recovery units equipped with static heat exchangers



### DESCRIPTION

- Frames consisting of rounded aluminium profiles with built-in, polyamide made, spacers for class TB2 thermal break; corners made of reinforced polyamide; double skin (sandwich), 10/10 panels (inner side with galvanized steel sheet, outer side with pre-laquered metal sheet (RAL 7035) with protective film); insulation through 25 mm high density (M0) mineral wool.
- 2 EC motors, independently adjustable, external rotor type, integrating safety thermal cut-outs, with backward curved impellers directly driven by ball bearings; 2 speeds adjustable during the installation.
- Air-to-air, counter cross-flow, aluminium made heat exchanger whose high performance, certified by Eurovent, exceeds 90% according to EN 308 standard.
- Circular branch connections with lip seals to grant the system air tightness.
- 100% inner automatic by-pass.
- 2 filters, respectively G4 on extracted air (stale) and F7 on (fresh) air

supply, both mounted upstream of inner components, on runners fitted with lip seals to ensure effective air tightness.

- Access to filters and inner components by security latch on removable panels.
- Brackets crimped into the structure for fixing to the ground or ceiling/false ceiling.
- Inner slanted tray to assure the proper condensate removal at product horizontally installed.
- A dedicated pressure switch constantly controls the airflow across each fan, which indicates the presence of a fault on any external device which can be connected on the clean contact on board of the machine.
- A podlockable local circuit breaker, mounted on front panel, allows to stop the unit in case of fault.
- Potentiometers to independently adjust each fan speed.

### ACCESSORIES



**POTI NRG**

Code 21039



**NRG EC 4F**

Code 21037

#### PER INFORMAZIONI:

Servizio al Cliente: tel +39 02 90699395 premendo 1 dopo messaggio registrato (consulenza su prodotti e impianti)

Pre & Post Vendita: fax +39 02 90699302

Email prevendita: [prevendita@vortice-italy.com](mailto:prevendita@vortice-italy.com)