



VORT QBK COMFORT ES RANGE

Energy saving sound-proof double inlet cabinet fans

PRODUCT SPECIFICATIONS

Ideal for residential, commercial and industrial ventilation: kitchens, bathrooms, offices, laboratories, factories, shops, laundry, restaurants, bars, theatres, ballrooms, etc.

LONG LIFE 30.000 h



- 5 models single phase.
- Flow rates up to 5500 m³/h.
- Extruded UNI 9006 aluminium frames assembled with diecast aluminium joints.
- Zinc treated sandwich panels, sound-proof through mineral wool (density 90/100 Kg/m³) covered with 48 mm layer of fibreglass.
- Fan motor units with dynamically balanced twin intake direct feed forward-curved centrifugal blades, made using galvanized steel (ISO standard 1940).
- Brushless motors, all in class F, with shafts turning in ball bearings and suitable for control with external potentiometer (signal 0-10 V), supplied as standard.
- 1 inspection panel with locking handle.
- 1 intake panel with smooth round nipple.
- 1 smooth round nipple on inlet vent.
- Operating temperature between -20 and +40°C.
- Protection rating: IP20.
- Insulation class: Cl.I ⊕.

Fans used in VORT QBK COMFORT ES range comply with ErP N° 327/2011/UE.





KEY FEATURES

- Low power consumption coupled with high performance thanks to brushless EC motors.
- Low noise emissions.
- Wide range of speed adjustment by means of an external potentiometer (signal 0-10 V).
- High dependability and reduced maintenance requirement.
- Designed for application in ventilation duct.
- Flexible installation thanks to being able to adapt the air delivery side to the system requirements by appropriately varying the arrangement of the removable panels of the enclosure depending on the needs of the system.
- The speeds of the fan units are adjustable with an external potentiometer included (0-5V or 0-10V DC signal).

TECHNICAL DATA

Models	Code	V ~ 50/60 Hz	W max	A max	RPM*	Max Airflow		Max Pressure		°C Max	IP motor	Kg
						m ³ /h	l/s	mmH ₂ O	Pa			
VORT QBK COMFORT ES 1000	45170	230	260	1.8	2100	1070	297	80	785	40	20	35
VORT QBK COMFORT ES 7/7 M	45171				2000	2850	792	60	588			
VORT QBK COMFORT ES 9/9 M	45172		1100	4.6	1450	3240	900	88	863		44	38
VORT QBK COMFORT ES 10/10 M	45173				1100	4250	1181	116	1138			
VORT QBK COMFORT ES 12/12 M	45175		1700	7.0	950	5500	1528	118	1157		54	79

* RPM measured at the point of maximum air flow.

The performance data are relative to the F.M.W.L. (Fan Max Working Limit) maximum use curve obtained with the highest DC motor setting.

VORT QBK COMFORT ES RANGE

Energy saving sound-proof double inlet cabinet fans

SOUND LEVELS

Models	Code	Speed	125 Hz	250 Hz	500 Hz	1000 Hz	2000 Hz	4000 Hz	8000 Hz	Lw dB (A)	Lp dB (A) 3m*
VORT QBK COMFORT ES 1000	45170	Max	19.6	41.6	38.6	38.7	40.1	41.3	36.2	52.6	32.1
VORT QBK COMFORT ES 7/7 M	45171		40.9	53.8	48.5	41.1	47.7	50.9	46.1	61.7	41.2
VORT QBK COMFORT ES 9/9 M	45172		48.6		48.4	48.1	46.2	47.2	39.3	61.6	41.1
VORT QBK COMFORT ES 10/10 M	45173		44.4	53.2	50.9	51.6	47.7	48.5	31.9	62.5	42.0
VORT QBK COMFORT ES 12/12 M	45175		49.6	56.0	53.6	53.3	46.8	46.5	30.8	64.5	44.0

*Sound pressure level measured at 3 m in free field conditions with long-cased appliance in delivery mode, in accordance with standard EN ISO 3741.

DIMENSIONS

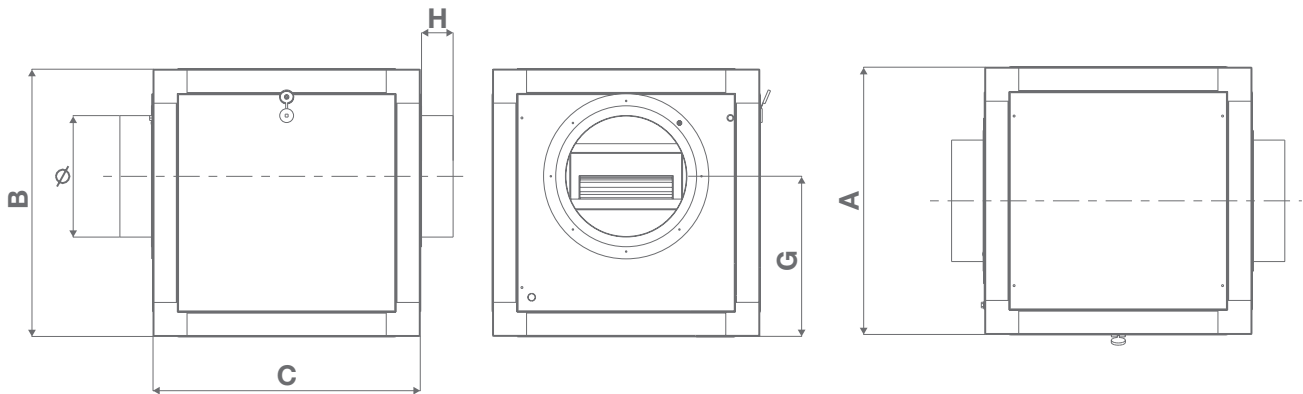

Models	A	B	C	G	H	Ø
VORT QBK COMFORT ES 1000	550	650	750	330	60	250
VORT QBK COMFORT ES 7/7 M				317.5		
VORT QBK COMFORT ES 9/9 M	450	750	750	375	90	400
VORT QBK COMFORT ES 10/10 M				450		450



Dimensions (mm)



VORT QBK
COMFORT ES
RANGE

CABINET FANS
ENERGY SAVING
SOUND-PROOF

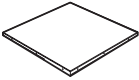
ACCESSORIES

	Description	Code	Product	
	QBK RRC COMFORT - Rain cover	7/7 - 9/9	24212	45170 - 45171
		10/10	24213	45172 - 45173
		12/12	24214	45175
	QBK F - Feet	24247	all models	

APPLICATIONS





VORT QBK COMFORT ES RANGE

Energy saving sound-proof double inlet cabinet fans

PERFORMANCE CURVES

— Delivery — Power consumption

VORT QBK COMFORT ES 1000

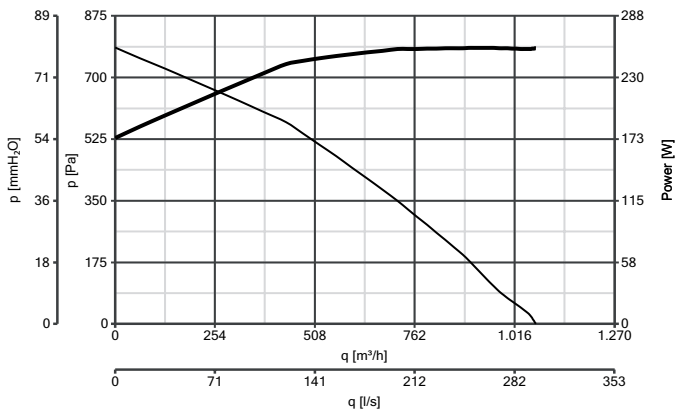

VORT QBK COMFORT ES 7/7 M

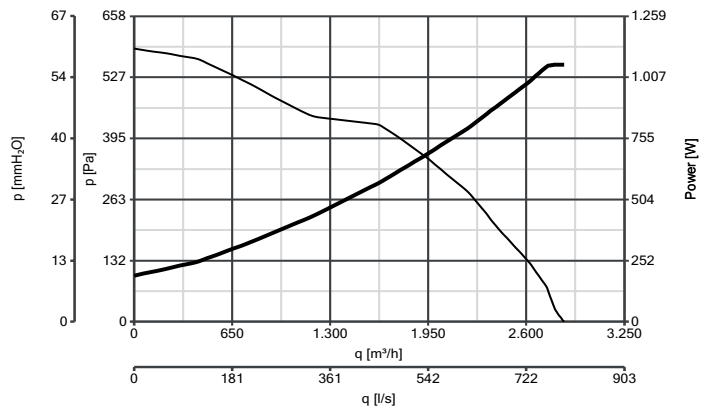

VORT QBK COMFORT ES 9/9 M

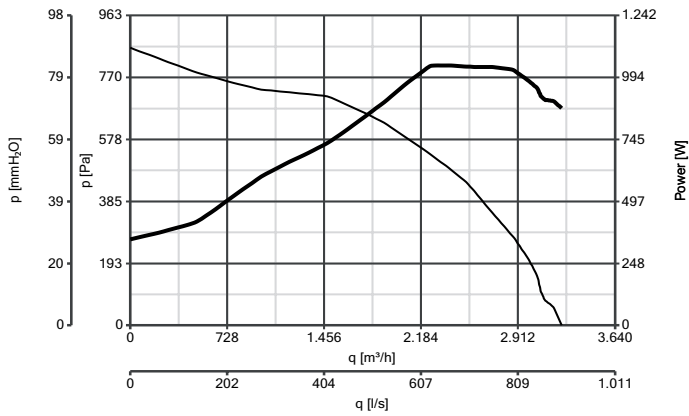

VORT QBK COMFORT ES 10/10 M

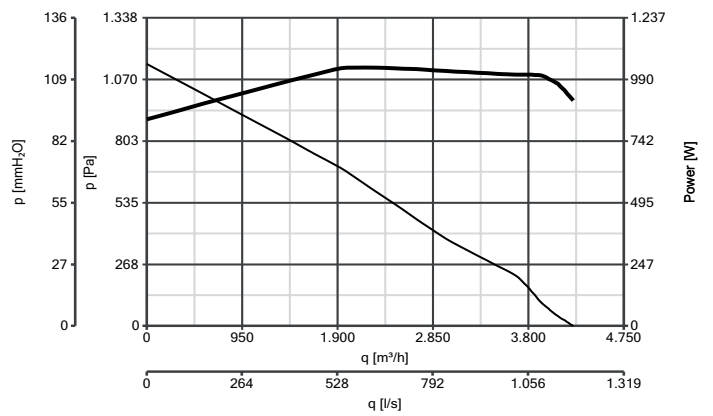

VORT QBK COMFORT ES 12/12 M

